



Modular Cooking Range Line 900XP 6 Drawer Refrigerated Base (60Hz)

ITEM # _____

MODEL # _____

NAME # _____

SIS # _____

AIA # _____



391605 (E9TTBPCOMKN)

Refrigerated base with 6 drawers, -2/+10° C, automatic evaporation of defrost condense - R290 (Brazil, Saudi Arabia)

Short Form Specification

Item No. _____

Refrigerated base with 6 drawers. Built-in refrigerator compressor unit. Operating temperature range from -2°C to 10°C. To be installed below 900XP top units. To be delivered with 50 mm height adjustable feet. Exterior panels in stainless steel with Scotch Brite finish. Suitable to operate with ambient temperature up to +43°C. Constructed to allow flush-fitting junction between units.

Main Features

- Unit can be easily installed below other 900 line top models.
- Adjustable temperature range from -2 °C to +10 °C to suit meat, fish and dairy storage requirements.
- Forced air circulation for rapid cooling and an even temperature distribution.
- Designed for modular installation into the cooking block.
- Anti-tilt runners accept GN 1/1 containers.
- Right angled side edges eliminate gaps and possible dirt traps between units.

Construction

- Built-in compressor to suit operating conditions.
- Access to all components from the front.
- Exterior panels in Stainless steel with Scotch Brite finish to meet the highest hygiene standards.
- Unit delivered with 150 mm height adjustable feet in Stainless steel. Feet can be extended up to 250 mm.

Sustainability



- CFC and HCFC free (highly ecological refrigerant type: R290).

Optional Accessories

- Flanged feet kit PNC 206136
- Frontal kicking strip for concrete installation, 1600mm PNC 206152
- Frontal kicking strip, 1600mm (not for refr-freezer base) PNC 206179
- Kit 3 base support for wheels PNC 206430
- Kit 6 wheels - 3 swivelling with brake PNC 206432

APPROVAL: _____



Experience the Excellence
www.electroluxprofessional.com

Front

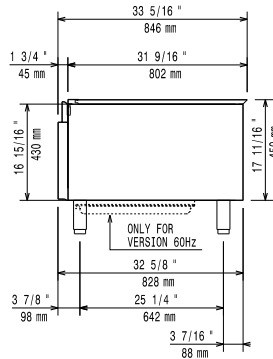

Side

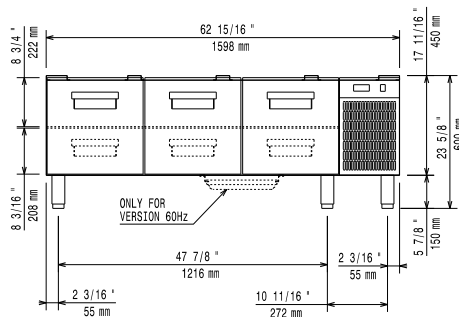

D = Drain
 EI = Electrical inlet (power)

Top

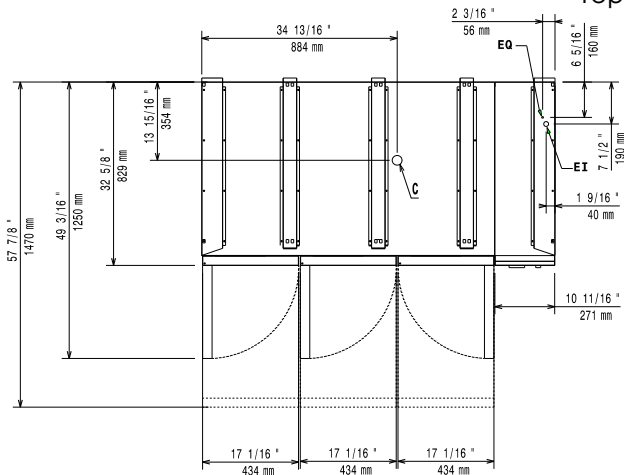

Electric

Supply voltage:

391605 (E9TTBPCOMKN) 220-230 V/1N ph/60 Hz

Electrical power max.:

0.4 kW

Total Watts:

0.4

Key Information:

Gross capacity:

240 lt

External dimensions, Width:

1600 mm

External dimensions, Depth:

830 mm

External dimensions, Height:

600 mm

Net weight:

110 kg

Shipping weight:

172 kg

Shipping height:

820 mm

Shipping width:

1300 mm

Shipping depth:

1700 mm

Shipping volume:

1.81 m³

Refrigeration Data

Compressor power:

Sustainability

Refrigerant type:

R290

Refrigerant weight:

85 g